

# Masport®

Technical Bulletin Issue 79 - February 2011

## SP Driving Gears Change

As part of the continuous process of improving the quality of our products, changes have been made to the SP driving gears on our self propelled mowers range. The old driving gears and pinions, which have 60 and 16 teeth are replaced with redesigned gear and pinions with 45 and 12 teeth, respectively. This will allow for a better meshing between the driving gears and pinions. At the same time, we standardized the width of the driving gears, using a spacer with the new driving gear to replace the old thicker driving gear. Starting in **May 2010** from serial number **7303554**, the new parts have replaced the old ones in production. Pictured below are the new and old gears, showing the differences between them.

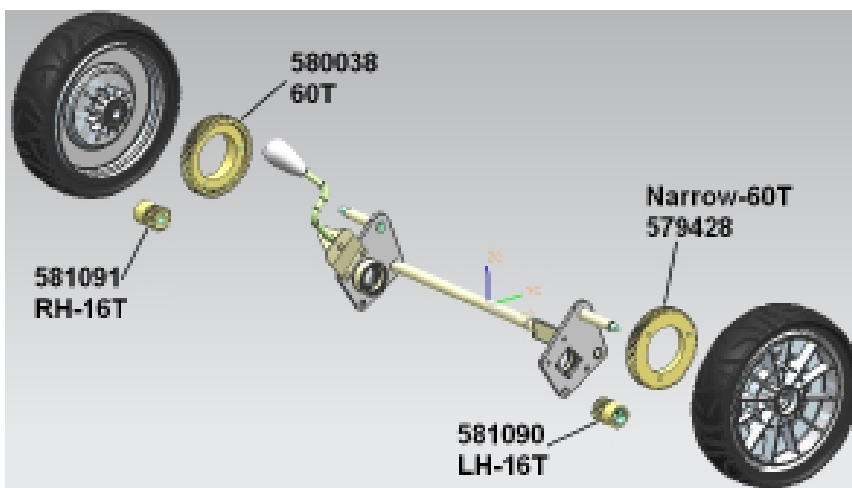

Old Driving Gears configuration

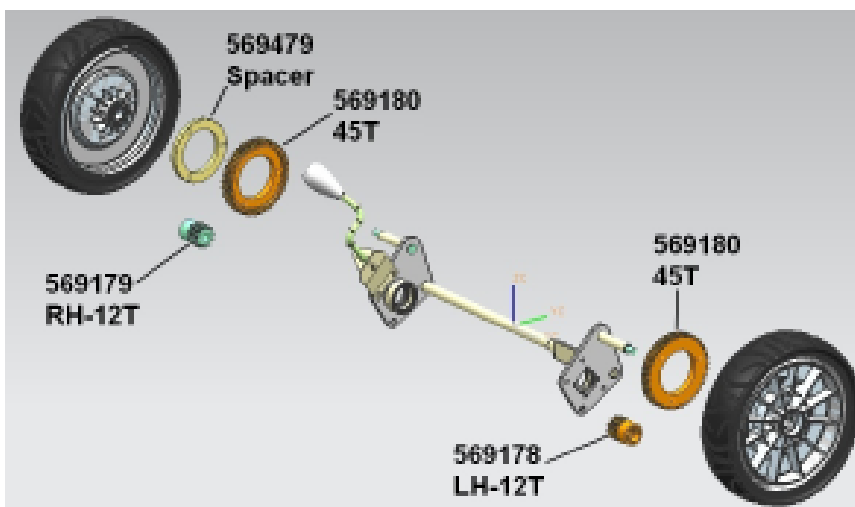

New Driving Gears configuration

This is an informative bulletin only.