

# K100 exploded view

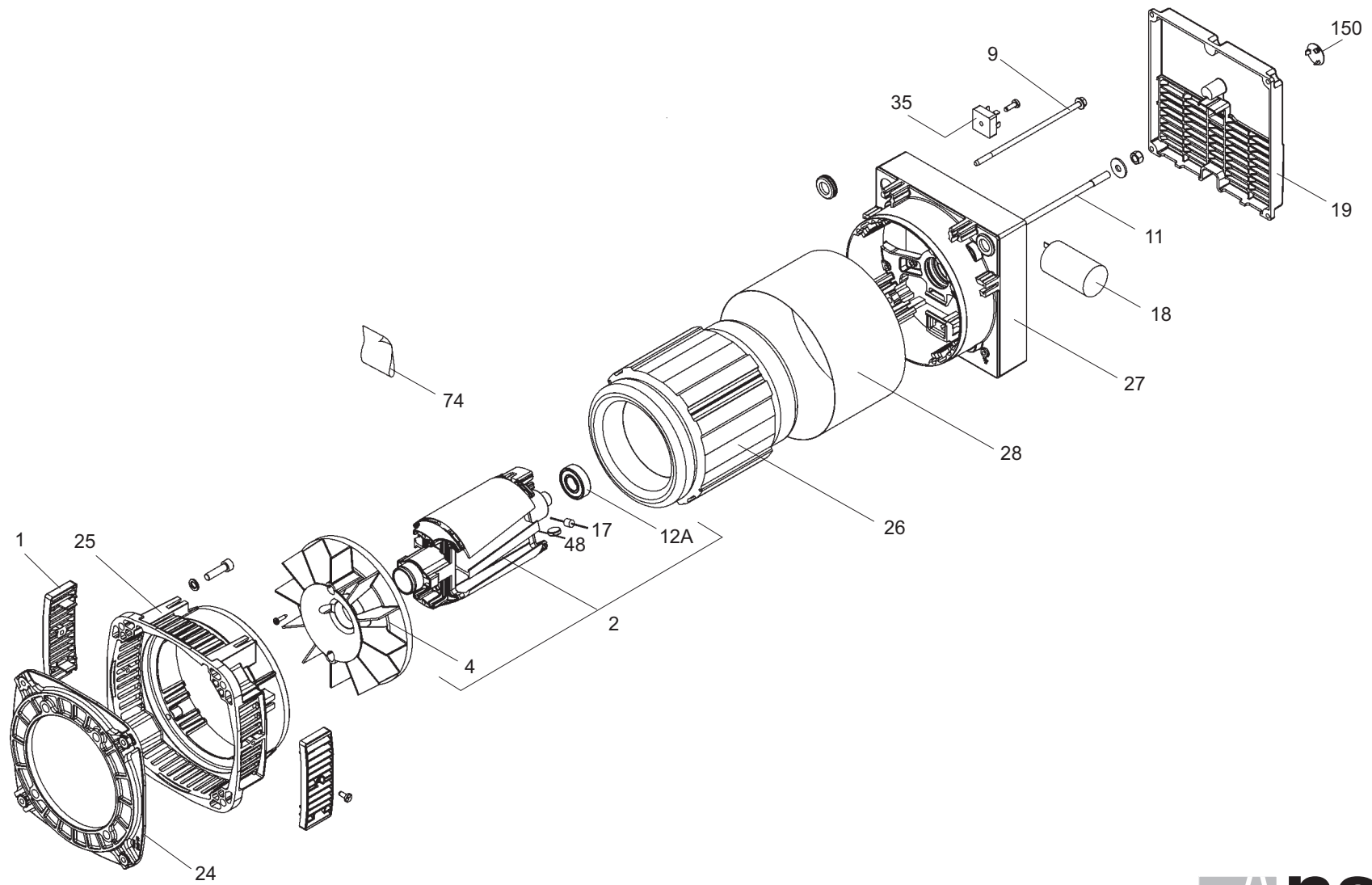

**Lista Ricambi K100 - K100 Spare Parts List - Pièces Détachées K100**

ref	qty	CODE	descrizione	description	description
1	2	1GGA10014	cuffia espulsione aria IP23	IP23 outlet grid	Grille de protection IP23
2	1	5AA12---	Rotore avvolto completo K100 D (4-12A-17-48)	complete Wound rotor K100 D (with 4-12A-17-48)	Roue polaire bobiné complet K100 D (avec 4-12A-17-48)
2	1	5AA12---	Rotore avvolto completo K100 E (4-12A-17-48)	complete Wound rotor K100 E (with 4-12A-17-48)	Roue polaire bobiné complet K100 E (avec 4-12A-17-48)
2	1	5AA12---	Rotore avvolto completo K100 F (4-12A-17-48)	complete Wound rotor K100 F (with 4-12A-17-48)	Roue polaire bobiné complet K100 F (avec 4-12A-17-48)
2	1	5AA12---	Rotore avvolto completo K100 FX (4-12A-17-48)	complete Wound rotor K100 FX (with 4-12A-17-48)	Roue polaire bobiné complet K100 FX (avec 4-12A-17-48)
2	1	5AA12---	Rotore avvolto completo K100 G (4-12A-17-48)	complete Wound rotor K100 G (with 4-12A-17-48)	Roue polaire bobiné complet K100 G (avec 4-12A-17-48)
4	1	1VGA10003	ventola	fan	Ventilateur
9	4	7VTE---	vite fissaggio scudi	Screws for bracket fixing	Vis pour fixation de flasques
11	1	7TZ---	Tirante rotore	rotor rod	Tige de roue polaire
12A	1	7CV62032R	Cuscinetto	ball bearing	Roulement
17	1-2	KDP6A12	Diodo rotore	rotor diode	Diode
18	1	7MEC013	Condensatore 13 µF 450V	Capacitor 13 µF 450V	Condensateur 13 µF 450V
18	1	7MEC014	Condensatore 14 µF 450V	Capacitor 14 µF 450V	Condensateur 14 µF 450V
18	1	7MEC018	Condensatore 18 µF 450V	Capacitor 18 µF 450V	Condensateur 18 µF 450V
18	1	7MEC030	Condensatore 30 µF 450V	Capacitor 30 µF 450V	Condensateur 30 µF 450V
18	1	7MEC035	Condensatore 35 µF 450V	Capacitor 35 µF 450V	Condensateur 35 µF 450V
18	1	7MEC040	Condensatore 40 µF 450V	Capacitor 40 µF 450V	Condensateur 40 µF 450V
19	1	1GGA10011	Cuffia aspirazione cieca	Blind cover	Couvercle arriere sans trous
19	1	91---	Kit coperchio chiuso+cavi	blind cover+cables kit	Kit Couvercle sans trous + câblés
19	1	91---	coperchio cablato	Wired cover	Couvercle arriere câblé
24	1	3FLA10010	flangia accoppiamento J609b C22-25,4	Coupling flange - J609b C22-25,4	Bride d'accouplement - J609b C22-25,4
24	1	3FLA10011	flangia accoppiamento J609a C19	Coupling flange - J609a C19	Bride d'accouplement - J609a C19
24	1	3FLA10012	flangia accoppiamento C23	Coupling flange -C23	Bride d'accouplement - C23
25	1	3SLA10015	scudo anteriore	drive end bracket	Flasque avant
26	1	5SA1308---	Statore avvolto K100 D	Wound stator K100 D	Stator bobiné K100 D
26	1	5SA1308---	Statore avvolto K100 E	Wound stator K100 E	Stator bobiné K100 E
26	1	5SA1308---	Statore avvolto K100 F	Wound stator K100 F	Stator bobiné K100 F

26	1	5SA1308---	Statore avvolto K100 FX	Wound stator K100 FX	Stator bobiné K100 FX
26	1	5SA1308---	Statore avvolto K100 G	Wound stator K100 G	Stator bobiné K100 G
27	1	3SLA10016	scudo posteriore	no drive end bracket	Flasque arriere
28	1	3APPL---	fascia di chiusura	enclosing band	Protection stator
35	1	KPD25A02	Ponte raddrizzatore per CB	B.C. rectifier bridge	Pont redresseur pour C.B.
48	1-2	KVZ14L781	Varistore	varistor	varistor
74	1	7ATSH10EM	sacchetto viteria	assembling screw kit	Kit vis pour l'assemblage
150	1	7PRTS0232	tappo di chiusura	plastic plug	Bouchon

nella richiesta di parti di ricambio, Vi preghiamo di comunicare sempre il tipo di alternatore/optional e le relative caratteristiche	On requesting of spare parts, please indicate always alternator/optional type and its characteristics	Nous vous prions d'indiquer toujours, dans vos commandes de pièces de rechanges, la description e les caracteristiques de la machine/optional
---	---	---